

Instruction Manual

Service Cart

SC4217

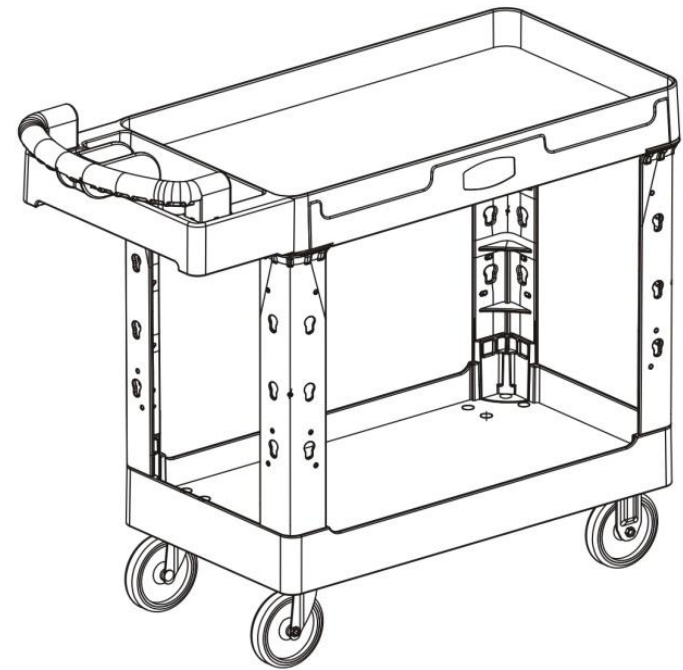

WARNING!

PLEASE DO NOT ASSEMBLE THE CART UNLESS YOU HAVE READ AND FULLY UNDERSTOOD THIS MANUAL.
FAILURE TO TAKE PRECAUTIONS AND FOLLOW SAFETY RULES
MAY RESULT IN SERIOUS INJURY.

IMPORTANT SAFETY INFORMATION



WARNING!

- Read and understand all instructions. Failure to follow all instructions may result in serious injury or property damage.
- The warnings, cautions, and instructions in this manual cannot cover all possible conditions or situations that could occur. Exercise common sense and caution when using this cart. Always be aware of the environment and ensure that the cart is used in a safe and responsible manner.
- Do not allow persons to operate or assemble the cart until they have read this manual and have developed a thorough understanding of how it works.
- Do not modify this cart in any way. Unauthorized modification may impair the function and/or safety and could affect the life of the cart. There are specific applications for which the product was designed.
- Use the right tool for the job. DO NOT attempt to force small equipment to do the work of larger industrial equipment. There are certain applications for which this equipment was designed. It will be a safer experience and do the job better at the capacity for which it was intended. DO NOT use this equipment for a purpose for which it was not intended.
- Industrial or commercial applications must follow OSHA requirements.

WORK AREA SAFETY

- Inspect the work area before each use. Keep work area clean, dry, free of clutter, and well-lit. Cluttered, wet, or dark work areas can result in injury. Using the cart in confined work areas may put you dangerously close to other cutting tools and rotating parts.
- Keep children and bystanders away from the work area while operating the cart. Do not allow children to handle the cart.

PERSONAL SAFETY

- Stay alert, watch what you are doing, and use common sense when operating the tool. Do not use the cart while you are tired or under the influence of drugs, alcohol, or medication. A moment of inattention while operating the cart may result in serious personal injury.
- Dress properly. Do not wear loose clothing, dangling objects, or jewelry. Keep your hair, clothing and gloves away from moving parts. Loose clothes, jewelry, or long hair can be caught in moving parts. Air vents on the tool often cover moving parts and should be avoided.
- Wear the proper personal protective equipment when necessary. Use ANSI Z87.1 compliant safety goggles (not safety glasses) with side shields, or when needed, a face shield. Use a dust mask in dusty work conditions. Also use non-skid safety shoes, hardhat, gloves, dust collection systems, and hearing protection when appropriate. This applies to all persons in the work area.
- Do not overreach. Keep proper footing and balance at all times.

SPECIFIC OPERATION WARNINGS



WARNING!

- Do not exceed the rated load capacity.
- Be aware of dynamic loading. A sudden loading movement may briefly create an excess load causing product failure.
- Do not allow riders.
- Use only on a hard level surface.
- Inspect before each use. Do not use if parts are damaged.

CART USE AND CARE









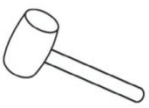

CAUTION!

- Do not force the cart. Products are safer and do a better job when used in the manner for which they are designed. Plan your work and use the correct product for the job.
- Check for damaged parts before each use. Carefully check that the cart will operate properly and perform its intended function. Replace damaged or worn parts immediately. Never operate the cart with a damaged part.
- Do not use a product with a malfunctioning switch. Any power tool that cannot be controlled with the power switch is dangerous and must be repaired by an authorized service representative before using.
- Disconnect the power/air supply from the product and place the switch in the locked or off position before making any adjustments, changing accessories, or storing the tool. Such preventive safety measures reduce the risk of starting the tool accidentally.
- Store the cart when it is not in use. Store it in a dry, secure place out of the reach of children. Inspect the tool for good working condition prior to storage and before re-use.
- Use only accessories that are recommended by the manufacturer for use with your cart. Accessories that may be suitable for one product may create a risk of injury when used with another tool. Never use an accessory that has a lower operating speed or operating pressure than the tool itself.
- Keep guards in place and in working order. Never operate the cart without the guards in place.
- Do not leave the tool running unattended.

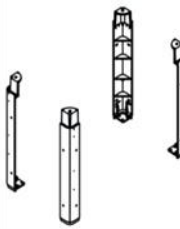
Required tools (Not included)

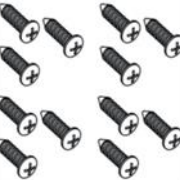
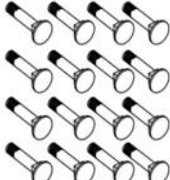
Screwdriver	Rubber mallet		
			

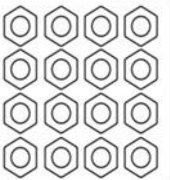
Parts List

1-Handle	2-Upper tray	3-Lower tray	4-Beam
			
5- Fixed Caster	6 - Swivel caster	7-M6 Screw-6x25mm	8-M8 Bolts-8x45mm
			
9 -SPRING WASHER	10 - M8 Nut	11-M6 Screw-6x42mm	12 - M6 Screw-6x25mm
			

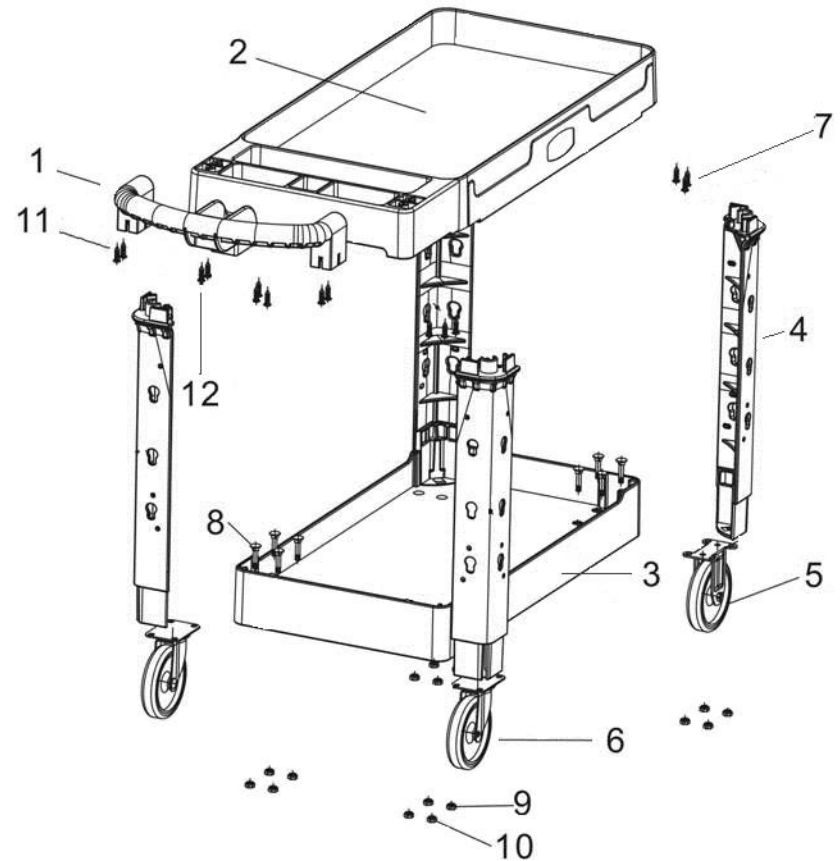

TECHNICAL SPECIFICATIONS

SC4425 Service Cart

Capacity	500 lbs.
Net Weight	30.8lbs.
Shelves	2
Product Dimensions	L 41.3" x W 16.97x H 34.6" (Handle Height)
Caster Size	5" x 1-1/4"
Caster Quantity	2 rigid + 2 swivel
Cart Material	PP
Casters Material	TPR (Thermo-Plastic-Rubber)

Reference	Part Number	Part Description	Quantity
1	SC4217-1	HANDLE	1
2	SC4217-2	UPPER TRAY	1
3	SC4217-3	LOWER TRAY	1
4	SC4217-4	BEAM	4
5	SC4217-5	FIXED CASTER	2
6	SC4217-6	SWIVEL CASTER	2
7	SC4217-7	M6 SCREW – 6 x 25mm	12
8	SC4217-8	M8 BOLT – 8 x 45mm	16
9	SC4217-9	SPRING WASHER	16
10	SC4217-10	M8 NUT	16
11	SC4217-11	M6 SCREW – 6 x 42mm	4
12	SC4217-12	M6 SCREW – 6 x 25mm	2

ASSEMBLY INSTRUCTIONS

Refer to the Parts Diagram for the following assembly instructions.

1. Set Beams (4) into Lower tray (3), See Figure A.
2. Place the two Swivel Caster Brackets on the same side of the Lower tray (2) as the Handle (1). Place the two Fixed Caster Brackets on the other side of the Lower tray (3). See Figure B. Insert Carriage Bolts (8) through the Lower tray (3) and into the Swivel Casters Brackets (6) & Casters Brackets(5) . Attach one Washer (9) and one Nut (10) for each hole.
3. Install upper tray (2), and turn the cart upside down, fix upper tray with screws (7). See Figure B.
4. Install handle (1) with screws (11) & (12).
5. Make certain that all hardware is tight. Make certain that the Fixed Casters and Swivel Casters roll properly.

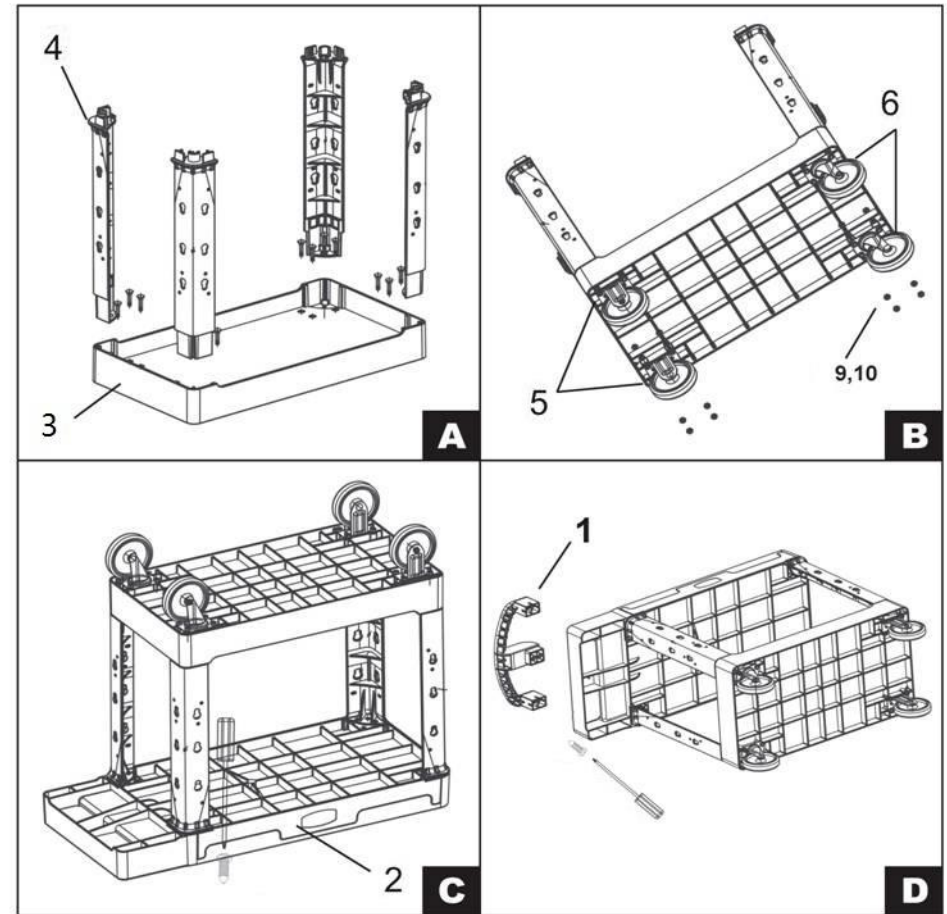
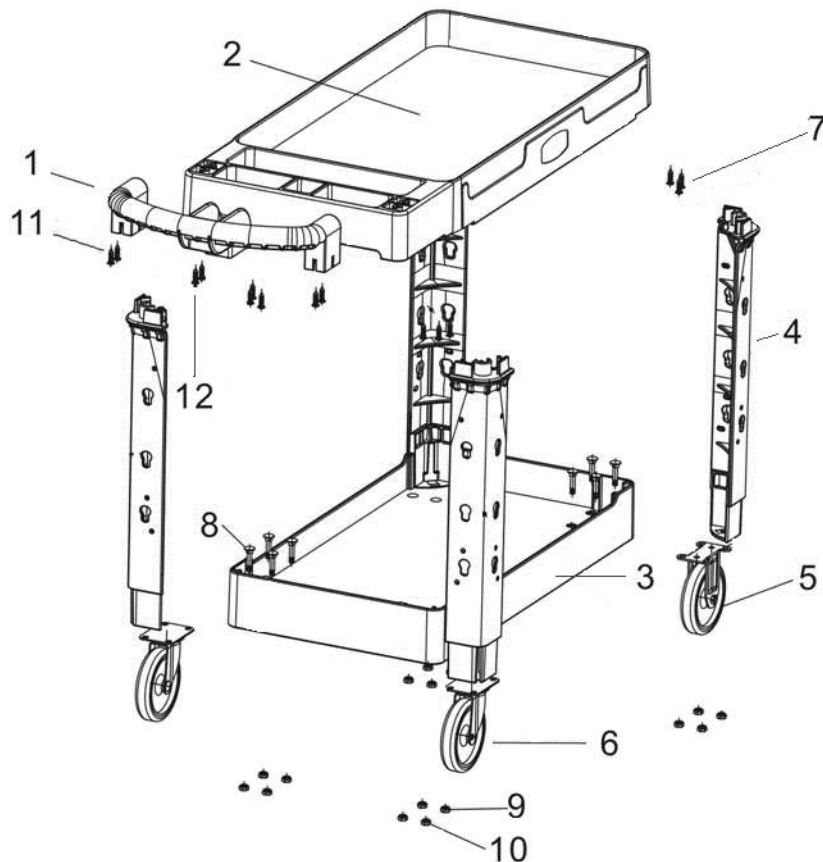

WARNING!

BEFORE EACH USE

Inspect the unit before every use; do not use if parts are loose or damaged.

AFTER EACH USE

Inspect the unit after every use; fix loose parts and replace damaged parts.



14728 Yorba Court,
Chino, CA 91710 USA
Tel: 1-877-779-2583
www.bpfasteners.com